

# PCR Retreading Machine Catalogue









## Equipment Features

- 1、 X / Y / Z **three-axis servo motor linkage**, automatically achieve spatial curve grinding, grinding precision.
- 2、 High degree of automation, less manual intervention.
- 3、 With thickness sensor and side perimeter sensor to ensure stable grinding process.
- 4、 Current control grinding, increase production efficiency.
- 5、 Double nut adjustment center, adapt to different width tires.
- 6、 Blade cooling device reduces grinding temperature and reduces blade wear.
- 7、 With **sidewall cleaning device for grinding the sidewalls**.

***\*Customized services accepted.***



## Technical Parameters

Rim Size	13" -18"
Tire Diameter	500-700mm
Tire Weight	Max 35kg
Productivity	10-20 piece/hour
Power	29.7Kw
Dimensions	2500x2100x2600mm
Weight	1800kg



## Equipment Features

- 1、 The operation of the system is simple, convenient, easy to use, reduce the labor intensity of the operator.
- 2、 High control precision can make the adhesive distributor work accurately in accordance with pre-set technological parameters, easily obtain the winding contour with good reproducibility, and improve the qualification rate.
- 3、 With independent temperature control system and water circulation system

*\*Customized services accepted.*



## Technical Parameters

Rim range	13" -19"
Rubber temperature	60-90°C
Screw type	MCT75x12D
Productivity	20-30 ( piece/hour )
Power	18.5Kw
Dimensions	3000x1000x1500mm
Weight	1400kg

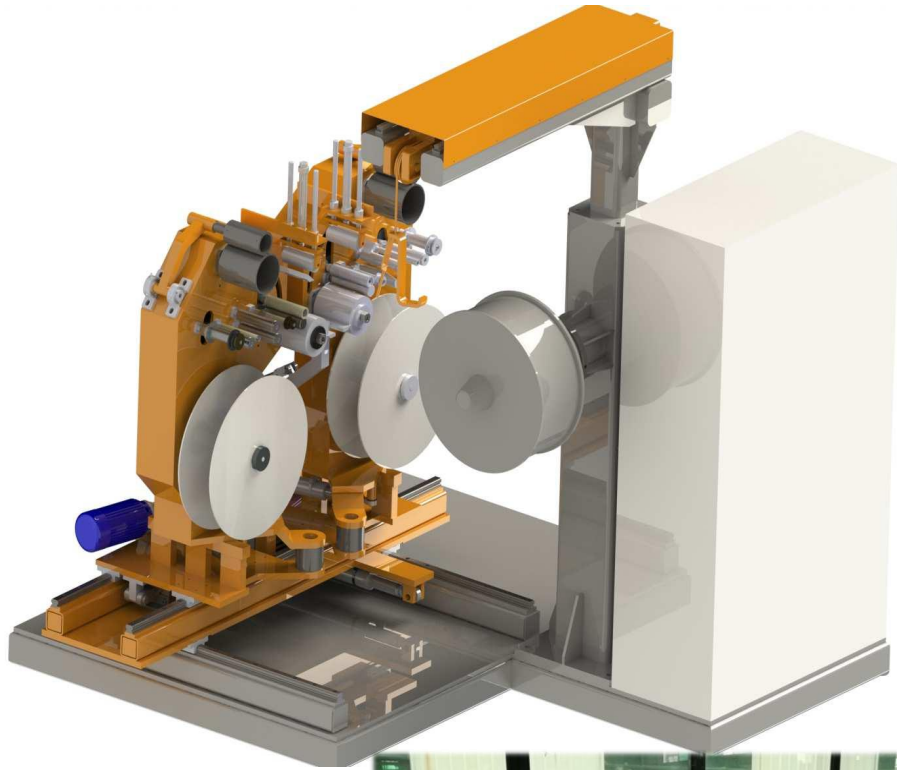

## Equipment Features

- 1、 Simple operation of equipment.
- 2、 The rubber fits evenly on the tire.
- 3、 Press to expel air.

*\*Customized services accepted.*

## Technical Parameters

Rim Size	13" -19"
Productivity	10-20 ( piece/hour )
Power	2kw
Dimensions	1750x1600x1400mm
Weight	1000kg





## Equipment Features

- 1、 Automatic temperature, pressure and timing controlling. Automatic curing data recording and saving. Equipped with data searching and printing function.
- 2、 The DPC pressure is accurately controlled. The warning and error detecting functions work well, due to the joint working of several security devices .
- 3、 Heating method of the chamber can be customized to electrical heating, steam heating or oil heating.

Technical Parameters			
Model	PLH-14	PLH-16	PLH-18
Tire Size	13"-205/55R16	195/80R15-265/60R17	235/85R16-285/70R19.5
Diameter of cavity	695mm	830mm	950mm
Height of cavity	190-230mm	230-280mm	250-300mm
Air consumption	1250Nit/h	1450Nit/h	1750Nit/h
Steam consumption	12kg/h	16kg/h	23kg/h
Power	1.5kw	1.5kw	2.25kw
Capability	2 hour/unit	2 hour/unit	2 hour/unit
Weight	1500kg	2300kg	3600kg
Dimension	1700×1550×1200mm	2100×1800×1300mm	2100×1950×1500mm

**\*Other specifications are subject to customization**

# PCR Cruing Press Moulds

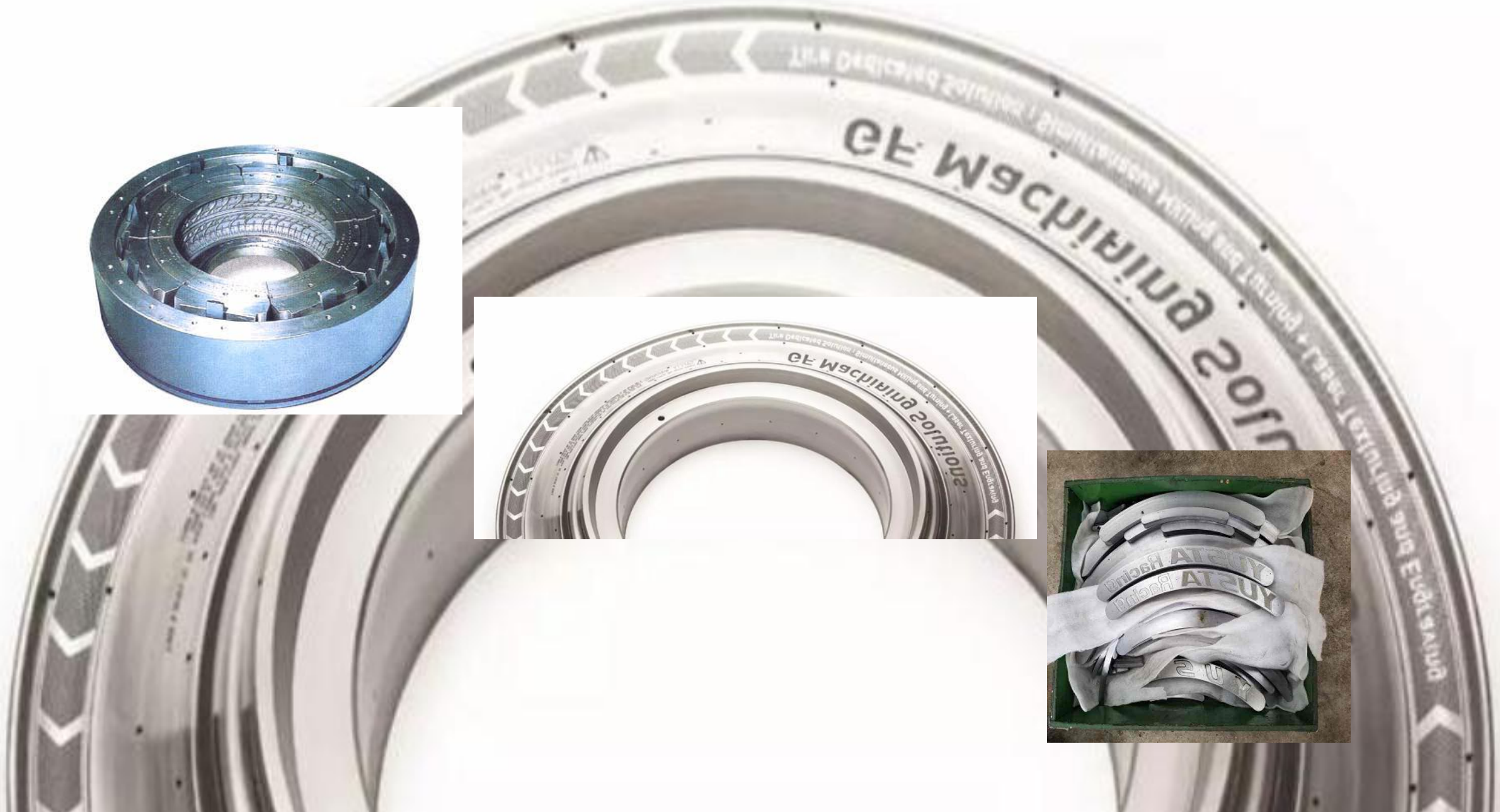
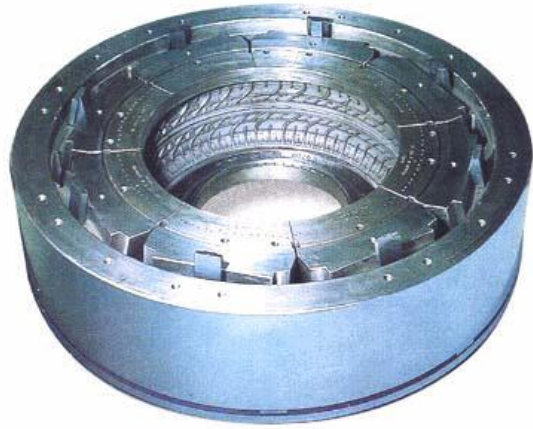





## PJ-20 PCR INSPECTION MACHINE

### Equipment Features

Used to inspect the casing from inside to outside to evaluate the safety of the tire and make the decision whether the tire can be retreaded. Find and mark all visible and repairable defects on the acceptable tires.

### Technical Parameters

TYRE SIZE:13"~20"  
 SIZE:800\*550\*600mm  
 WEIGHT:150KG  
 POWER:1.5KW  
 Voltage:220/380V,50HZ



## PC-20 Rubber Cement

### Equipment Features

The glue is used to apply on the polishing surface of the tire to prevent rubber oxidation and increase rubber adhesion. Rubber Cement is used for supply a Room and vacuuming station. It can be an optional.

### Technical Parameters

External dimensions 1500\*1200\*2500mm;  
 Power 2.5Kw;  
 weight: 500Kg.



## PJ-20 PCR INSPECTION MACHINE

### Equipment Features

PJ-20 is used to identify the recycling of waste tires have retreading condition and after retreading whether meet the requirements of use. It can achieve flaw test of tires, such as strength test for tires, leakage test of tires, swelling test of tires, etc.

### Technical Parameters

Tire size: 13"~20"  
 Working pressure: 0.2~ 1MPa  
 Capability: 40~50 unit/hour  
 External dimension: 2000\*1450\*1900mm  
 Weight: 1500Kg



## Rubber Cement Mixing MACHINE

### Equipment Features

Used for mixing glue to prevent solidification.

### Technical Parameters

External dimensions 950\*950\*1100;  
 Effective capacity 80L;  
 Power 750W;  
 The maximum setting time is 99 hours;  
 Mixing time of the glue for 8-16 hours;  
 weight: 165Kg



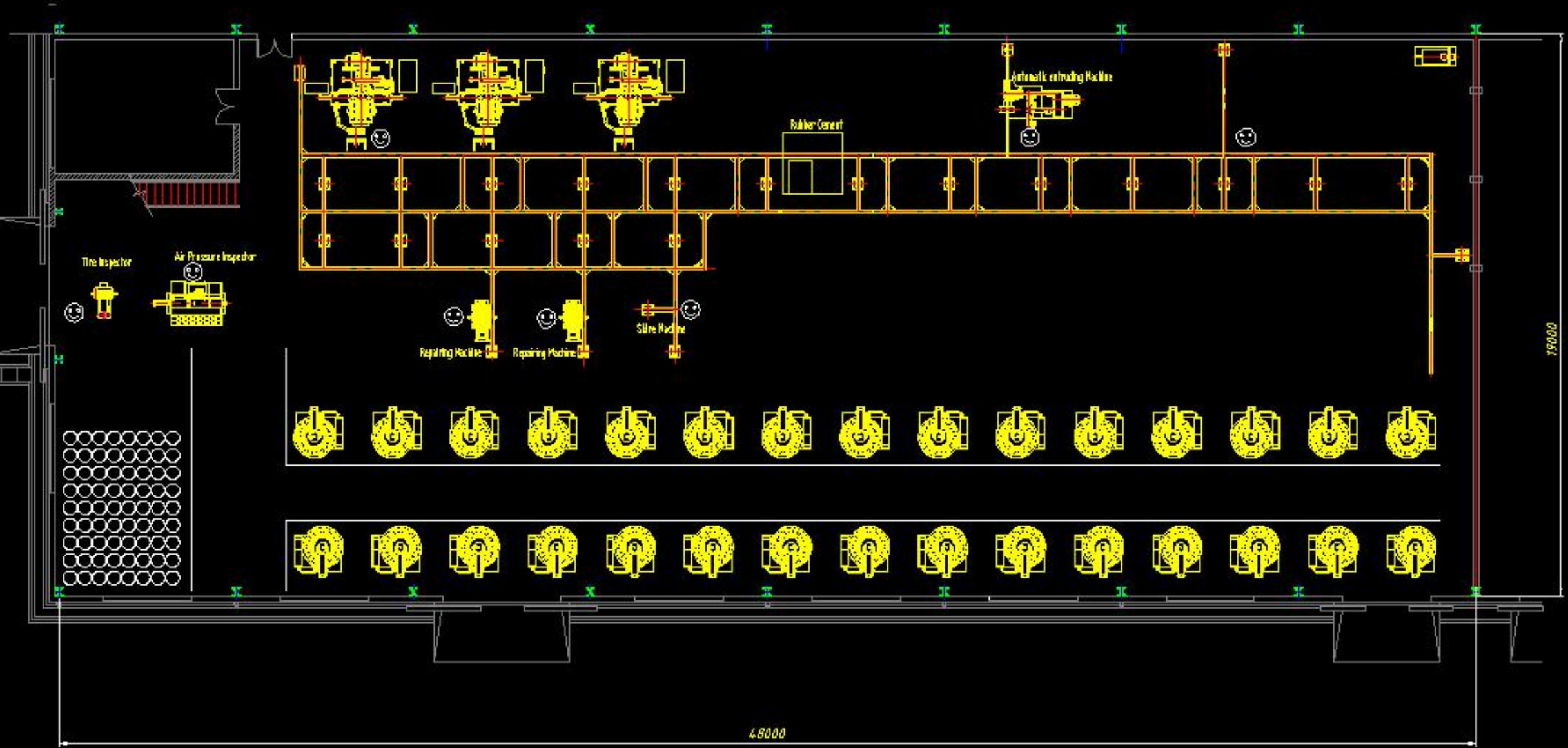

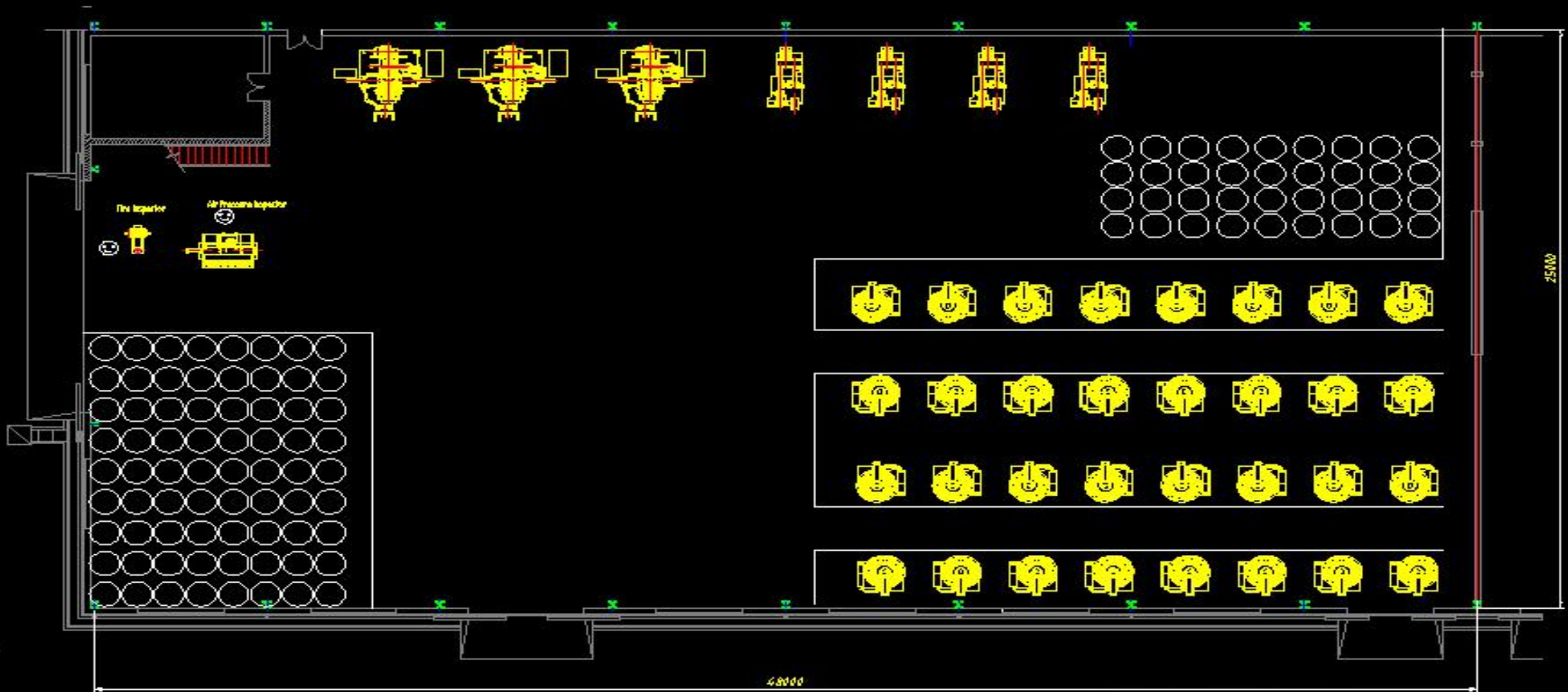

Mark	the file number	operator				
the year		date		sign	number, sign	number
number		year				100
date					page	
other						



FINISHED PCR TIERS





THANK YOU FOR YOUR INTEREST  
IN OUR PRODUCTS!

[www.int-besttyre.com](http://www.int-besttyre.com)

